

Final Report of UTA Large Perpetual Cloud Chamber Research Project

M. Blocker, H. Brown, K. Crawford, J. Creel, C. Dobbs, P. Duarte, J. Foley, R. Gbur,
J. Jette, C. Medina, J. Murphree, L. Price, J. Smith, S. Spivey, S. Suddath, D. Thomas,
P. Weatherly

Supervising professor: Dr. J. Yu
Physcs Department, University of Texas, Arlington, TX 76016

January 29, 2007

Abstract

This document presents the final report of UTA's large perpetual cloud chamber (LPCC) research project. During the past year, we held six workshops and constructed three prototype chambers of varying sizes. The prototype cloud chambers were built with improved technology available. Through the research activities, we have completed all research topics and come to conclusions on all components of the LPCC. We finalized the structure and the dimension of the chamber. We made a decision on lighting technology as well as the filtering mechanism on the display chamber to cut down glare for bright public area operations, using glare reducing films. We have a design to construct high luminosity light using LEDs and the angles and the coverage to reduce reflections from the liquid surface. We have finalized the design of liquid supply system that would allow virtually perpetual operation of the chamber. We have studied the behaviors of Thermoelectric Modules (TEM's) for an advanced, perpetual cooling and have learned that this technology is a bit premature for us to use for LPCC, and have decided to explore a way to purchase pre-manufactured cooling system that could provide us sufficient gradient at a reasonable cost. Based on the research presented in this report, we are at the level to seek funds to construct an LPCC. The largest prototype chamber is prepared for semi-perpetual running for display until the LPCC is completed.

1. Introduction

The University of Texas at Arlington's Society of Physics Students conceived of constructing a large size, $1m(H) \times 2m(L) \times 1m(W)$, vertical display cloud chamber to be exhibited in a prominent area of the newly constructed Chemistry and Physics Building (CPB), next to the Planetarium which is the largest in the state of Texas. This chamber was originally to have ten individual layers stacked on top of each other to provide sufficient vertical tracks on the 1m height. This project started in September 2005 as part of the World Year of Physics celebration and became a joint project between the students from physics and chemistry departments since the chamber involves both physical and chemical phenomena. This chamber is also expected to serve physics and chemistry students' educational purposes, such as undergraduate Nuclear and Particle physics course in the physics department. Most of all, however, this chamber will provide planetarium visitors a permanent display of charged particle tracks from invisible cosmic

rays or background radiation on earth and provide inspiration to K-12 students on the wonders of science and nature in conjunction with spectacular planetarium shows.

In order to accomplish the goals of constructing such a large scale chamber that has never been built for a university display, a group called the UTA Large Cloud Chamber Society (UTA-LCCS) has been created and held three workshops in 2005. In order to push forward the project, a group of students from SPS proposed a research project to the national chapter. The project was selected as one of the six awarded in 2006.

The research items described in this report were accomplished using the funds from the award. UTA-LCCS held additional 6 workshops during the funding period in 2006 and has come to conclusions on virtually all research items we proposed in the original proposal. We have also been provided sizable additional support from the department of physics of the University of Texas at Arlington as part of the nuclear and particle physics special projects.

2. General Design Requirements

Given the purpose of LPCC and its anticipated public location, LPCC must meet the following general requirements:

- The chamber must be safe and reliable.
- The chamber must have large mean time between failures.
- The chamber must be able to recover automatically from possible power or other types of failures.
- The chamber must need minimal maintenance.
- The chamber must be aesthetically pleasing and intellectually stimulating to an audience of all ages.

3. Chamber Structural Design, Light and Display

Our motivation for the design is to research which design would work well with the cooling system and be structurally most stable under the large temperature variation. During the construction of the first large prototype chamber we learned that we need tighter grooves on the edges so that the glued sides of the chamber are structurally sound, by keeping alcohol from seeping into the joint and dissolving glue. We also applied marine sealant on the glued joint for additional protection.

For the chamber material, we have decided to use ½” polycarbonate plastic early on because it is able to withstand the high temperature gradient and variations anticipated in chamber operations. We have been using dry ice for the prototype chamber, but want to design the chamber so that the cooling system is perpetual. Three different sizes of prototype chambers were constructed to help us in deciding the best design for 10 layer version of LPCC.

3.1 Design Requirements

Many things must be taken into account when considering the structural design of the perpetual cloud chamber. The final design must be aesthetically pleasing and match the style and décor of the area in which it will be placed. This should be easy to achieve by choosing the appropriate laminates with which the exterior of the chamber base and lighting boxes will be covered.

The chamber must also be structurally sound and as safe as possible to avoid accident or injury to the wide range of viewers that will be visiting the display. Structural integrity can be accomplished by using quality building materials and appropriate construction techniques. Minimizing the number of sharp edges and corners will enhance

the safety of the design. The viewing chamber must be well sealed to prevent leakage of alcohol liquid or vapor as this would be a health and fire hazard. To prevent these risks, appropriate gasket materials and sealants will be used, and the viewing chamber will be isolated from the exterior by a glass case that will surround it. The exterior glass case will also protect the viewing chamber from scratching and contamination which could visibility. The underside of the viewing chamber will have to be well insulated with Styrofoam or another appropriate insulating material to prevent anyone from coming in contact with the extreme temperatures that are necessary to operate the chamber.

The viewing chamber needs to be well lit and visible from all angles. The lighting will be achieved by the construction of lighting boxes that will be attached along all sides of the viewing chamber. The lighting boxes will consist of rows of high intensity LED bulbs backed with mirrored plastic film to focus the light into the box. It may or may not be necessary to coat the outside of the viewing chamber with a glare reducing film to reduce the effect of ambient light or the chamber could be constructed with tinted polycarbonate. More detailed study of light and display is described in section

The base of the chamber needs to be able to accommodate and allow access to all of the equipment necessary for the operation of the chamber. Shelves can be added to the interior as necessary to support equipment. To allow access to the equipment there will need to be doors on at least one side. The use of inlaid doors with concealed hinges and a cam lock will maintain an attractive appearance and prevent unauthorized access to the interior of the chamber.

It may be necessary to ventilate some of the equipment. This can be accomplished by adding vent covers to one or more side of the base and possibly an exhaust fan. If it is necessary for the whole apparatus to be mobile, locking wheels may be added.

3.2 Prototype Chambers

Figure 1 shows a schematic diagram of these prototype chambers. The design employs a fitting mechanism in the corners of the polycarbonate plastic that allows tight mechanical fit and prevents alcohol from seeping into the glue joint and weakening it.

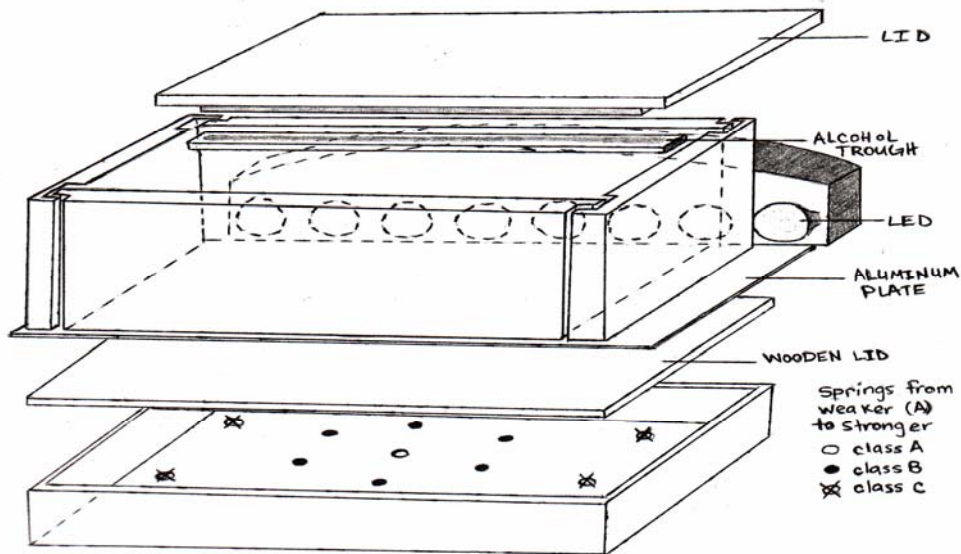

Figure 1 A schematic diagram of prototype chambers. The design employs a fitting mechanism between polycarbonate side plates that prevents any liquid from seeping into the joint, weakening the seal.

We find that this design provides sturdiness for the chamber and keeps its mechanical integrity.

The second chamber (CC#2) constructed is of medium size and has the dimensions $30\text{cm}(L)\times 10\text{cm}(H)\times 20\text{cm}(W)$. The cooling and lighting setups used are the same structures used for the large chamber (CC#1). This chamber was built to test the operation of the detector with far shorter height than the normal. We used this chamber to test the temperature gradient with the warm alcohol heated up to 50°C as described in section 6.

The first chamber (CC#1) of size $50\text{cm}(L)\times 30\text{cm}(H)\times 30\text{cm}(W)$ is our largest and operates with 99% isopropyl alcohol and dry ice. It is equipped with two troughs attached at the top inside to hold the alcohol in addition to a thin layer of super saturated alcohol covering the floor of the chamber. (Only one trough is shown in the drawings for simplicity. The other is attached on the opposite side.) The bottom surface is made of $1/8''$ aluminum plate for the even temperature dispersion using dry ice. It is painted non-reflective black to clearly view the tracks caused by incoming cosmic rays or background radiations. A hollow box with eleven springs supports a wooden lid that in turn supports dry ice blocks to keep them in tight contact with the aluminum plate. A tightly fitted lid rests on top to isolate the chamber from environment. This constant cool temperature combined with the alcohol creates our desired cloud. The prototypes employed eight LED light bulbs of 2.5W and 110V connected in series, illuminating the cloud and its tracks.

The smallest chamber has dimensions of $15\text{cm}(L)\times 15\text{cm}(H)\times 15\text{cm}(W)$ and the lighting system consists of three LED's in series borrowed from the larger system, as shown. This chamber was built to test the cooling with Thermoelectric Modules (TEM's) described in Section 5, which we hoped to revolutionize the cloud chamber.

Once we prepared the $1/2''$ thick polycarbonate plates by properly grooving them, we used Weld-on #16 polycarbonate adhesive by IPS Incorporation to glue the parts together. All the corners were then sealed using marine sealer to prevent alcohol seepage in addition to strengthening the chamber's mechanical structure. In order to prevent the bottom plate's distortion from destroying the chamber, the plate is not glued to the polycarbonate side walls. We find that once the even temperature distribution is accomplished on the plate, the polycarbonate side plates form a tight seal and the alcohol does not leak excessively. We, however, will research a way to glue the plate to the polycarbonate sheets for the final version of the large cloud chamber for safety and minimization of chamber maintenance.

3.2 Light System

In order to meet the need for an LPCC, the bulbs must put out a large amount of light, using as little electricity as possible and generating minimal heat since the heat will affect the chamber operation due to the temperature variation. The bulbs also must have a long lifetime so that minimum maintenance is required to keep the chamber operational uninterrupted. We studied both compact florescent bulbs and the bulbs consisting of a large number of Light Emitting Diodes (LED's). Both of these were rated able to put out sufficiently large amounts of light using very little power, typically less than 20W. Both types of bulbs put out light with very high temperature (6500K, close to sunlight). For a comparison, we used a flood light bulb with the light color close to yellow.

After operating our prototype chambers under these three different kinds of light, we found that while the tracks are visible in both LED and flood light bulb, the flood lights seemed to display tracks better. We determined that this was due to the color of light and its contrast to the bottom plate painted in non-reflective black.

On the other hand, we have found that the type of compact florescent light bulbs we purchased is very difficult to use in the cloud chamber setting due to their shapes. Since the power consumption by compact florescent light bulb and the LED bulbs are about the same while the life time of LED's and the shape of them are far easier to use in the cloud chamber structure, we decided to use LED bulbs for the display.

One remaining item in this topic was the final color of the LED bulbs. For this, instead of using different colored light bulbs, we used various color gel films which are normally used for theater plays to control the color of the light. We used yellow, red and blue and found that blue performs the best. We interpreted that this was because of the fact that the blue cuts down the scattering of the light on vapor molecule, enhancing tracks that are caused by energetic particles, while low energy particle tracks are mostly filtered. We tested this by putting the prototype chamber out on display and asking few passers by to tell us if they can identify tracks better. Over 50% of the people could identify tracks immediately.

The light system should not only minimize glare from the scattering on the supersaturated vapor but also the reflection from the liquid surface accumulated on the bottom aluminum plate of the chamber. Our initial choice, pre-manufactured LED bulbs consist of 48 small size LEDs and cost about \$40/bulb. While these bulbs satisfy most of the requirements above, since the diameter of the bulbs are 5cm, the total cost to cover a 2m long surface would be over \$1600. Also due to the fact that the shape of the bulb surface is circular, large number of LEDs in the bulbs illuminates unnecessary area of the chamber.

In order to overcome these issues, we purchased high luminosity 1cm diameter LEDs and bread circuit boards and to design and build our own LED light strip which utilizing two rows of LEDs, bread circuit boards and thin plastic reflector. Figure 2 shows a photograph of a prototype light strip we constructed for the large prototype (CC#1) chamber. This is designed to cover three sides of CC#1 viewing chamber and thus the



Figure 2 A photograph of the light strip constructed with 1cm LEDs and bread boards.

dimension is $30\text{cm}(D) \times 50\text{cm}(L) \times 30\text{cm}(D)$. The light strip was constructed with two rows of LEDs so that it illuminates only the limited area of the bottom of the chamber, minimizing the glare and the reflection. The 500 LEDs we purchased for prototype light strip costs \$152 including shipping. The brightness of each of these LEDs is rated at 130,000 mcd which is equivalent to the brightness of an unfocussed 100W incandescent bulb. Each of these LEDs draws 20mA with the forward DC voltage of 3.8V and reverse bias voltage of 5V. So the power consumed by each of these LEDs is 100mW. These LEDs are rated to last 100,000 hours.

3.3 Final Structural Design

The final design of the perpetual cloud chamber consists of a laminated wooden base and a polycarbonate viewing chamber surrounded by a glass case, as depicted in the schematic diagram in Fig. 3. The base will be constructed out of $\frac{3}{4}$ inch cabinet grade plywood that will be laminated to make it attractive. It will have shelves in the interior to accommodate the necessary equipment and inlaid locking doors for access to the equipment. Ventilation covers will be added as required.

The base will be approximately 220 cm wide, 70 cm deep, and 90 cm in height. The polycarbonate viewing chamber will be 200cm (W) \times 50cm (D) \times 50cm (H) and can be purchased pre-assembled from Regal plastics.

Surrounding the base of the viewing chamber will be four lighting boxes made of $\frac{1}{2}$ inch pine or maple that will be laminated. Inside of each lighting box will be many 10 millimeter LED bulbs back with mirrored plastic to act as a reflector. Two of the lighting boxes will be 200 cm in length and approximately 10 cm in height and depth. The other

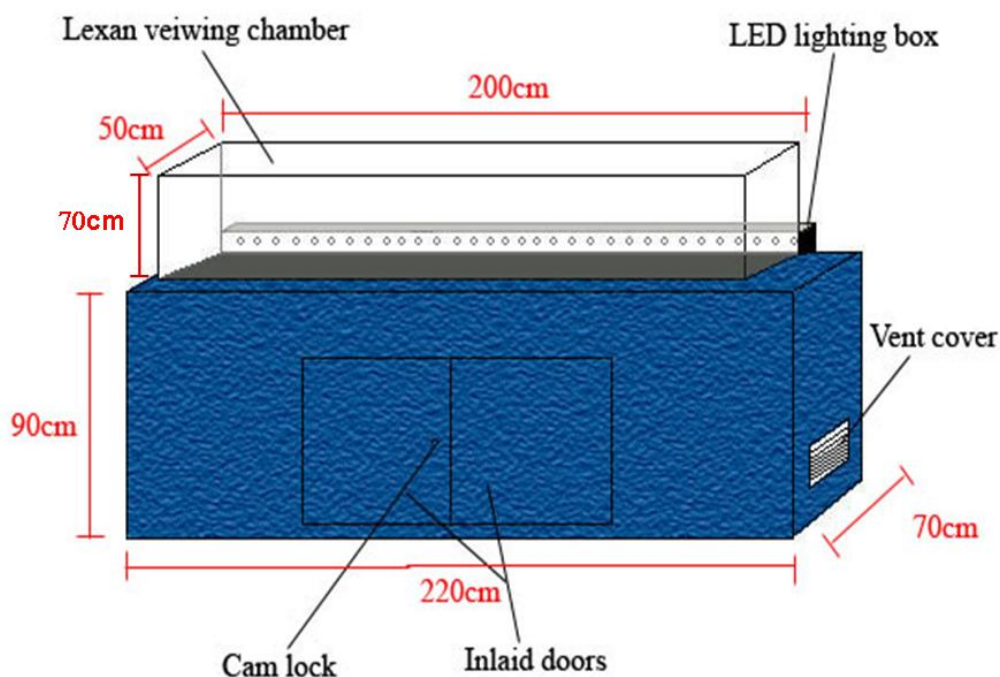

Figure 3 A schematic diagram of the final design. Exterior glass case and additional light boxes are not shown in the figure.

two will need to be 50 cm in length and will have the same height and depth.

Surrounding the viewing chamber will be a glass case consisting of five pieces of ¼ inch tempered glass connected together with aluminum channel and silicon. Two of the glass plates will be 60 cm by 220 cm. Two will be 60 cm by 70 cm. The top piece will be 220 cm by 70 cm. The glass can be purchased from Binswanger Glass Co. precut and tempered.

3.4 Cost Estimate for Final Design

Based on the research we carried out through the past year, we have decided to build one layer large scale chamber since the cost for each layer sufficiently large to build more than one. In addition, as described below, the TEM based cooling system turned out to be unreliable and costly just for the construction. In addition, TEMs draw significant DC power (100W each) which requires significant low voltage DC power supply. As described in the cooling system section, we had to abandon the use of TEM for perpetual cooling of the chamber but to look for more traditional liquid nitrogen based pre-manufactured system. Given our limited expertise on nitrogen cooling, the safety of the public also concerns us since sudden release of LN2 would cause oxygen deficiency hazard. These commercially available cooling systems allow us to control temperature of the cooling element in a wide range of temperature but are bulky.

For these reasons we decided to construct one layer, large scale chamber instead of constructing a 10 layer chamber. Table 1 below summarizes the cost estimate of the items necessary to construct an LPCC as specified in the final design.

* The price for the lexan box is still unknown. Regal plastics inc. was contacted at 817-429-5349 for a quote but did not provide one yet. Having ordered materials from Regal before, it is assumed that it would cost less than \$300.

Table 1 Cost estimate for constructing LPCC base, viewing chamber and the exterior glass window. Cost for some items still need to be negotiated.

Description	Quantity	Cost
4' by 8' ¾ inch cabinet grade plywood	3	\$150
1' by 12' ½ inch pine or maple	1	\$20
Concealed hinges for inlaid doors	4	\$15
Key operated cam lock	1	\$6.50
Vent covers	2	\$5
4' by 8' sheet standard grade laminate	3	\$200
Gallon contact cement	1	\$6.50
Fixed castor	2	\$20
Swivel castors locking type	2	\$25
Box plastic mirrored film	1	\$38
Wire grommets for electrical cords	2	\$10
LED bulbs	1000	\$320
Breadboard power distribution system	500cm	\$500
50cm×50cm×200cm lexan box	1	See note *
60cm by 220cm ¼ inch tempered glass	2	See note **
60cm by 70cm ¼ inch tempered glass	2	See note **
70cm by 220cm ¼ inch tempered glass	1	See note **
Aluminum channel for connecting glass		See note ***
Hardware for construction		\$50

** Binswanger glass co. at 817-274-1671 provided an estimate for all pieces for the amount of \$483.23. With the 30% contingency it will be \$628.20

*** The aluminum channel has not been located yet.

Most of the parts for construction of the base can be found at Home Depot, which is where most of the known prices have come. For all other materials, contact information has been provided. Adding all known prices plus estimates the total construction price comes out to \$1178.42. When the 30% contingency is added, it comes out to \$1531.95

Contact information

- Lexan box – Regal Plastics Inc. 817-429-5349
- Tempered glass – Binswanger Glass Co. 817-274-1671
- Laminate and contact cement – Wilsonart Inc. 214-634-2310
- Aluminum channel – To be determined

The structural design presented has some room for improvements or suggestions that would improve the quality and cleanliness of the chamber. A possible lighter shade for the glare reducing film would allow for more light and possibly more visible tracks. Up-grading the laminate to premium quality would improve the design aesthetically. The addition of some decorative trim to round off the corners would also add to the appearance.

4. Display System and Color Combination

In order to meet the need for a perpetually running cloud chamber, the bulbs must put out a large amount of light, using as little electricity as possible and generating minimal heat since the heat will affect the chamber operation due to the temperature variation. The bulbs also must have a long lifetime so that minimum maintenance is required to keep the chamber operational.

We studied both compact florescent bulbs and the bulbs consisting of a large number of Light Emitting Diodes (LED's). Both of these were rated able to put out sufficiently large amounts of light using very little power, typically less than 20W. Both types of bulbs put out light with very high temperature (6500K, close to sunlight). For a comparison, we used a flood light bulb with the light color close to yellow.

After operating our prototype chambers under these three different kinds of light, we found that while the tracks are visible in both LED and flood light bulb, the flood lights seemed to display tracks better. We determined that this was due to the color of light and its contrast to the bottom plate painted in non-reflective black.

On the other hand, we have found that the type of compact florescent light bulbs is very difficult to use in the cloud chamber setting due to their shapes. Since the power consumption by compact florescent light bulb and the LED bulbs are about the same while the life time of LED's and the shape of them are far easier to use in the cloud chamber structure, we decided to use LED bulbs for the display.

As the final research project, we have tested various color combinations between the light which determines the color of the track and the background. Instead of purchasing bulbs of various colors, we decided to use the existing LED bulbs but use plastic gel filters. We put dark yellow, red, brown and dark blue plastic sheets on the display portion of the chamber and observed the clarity of the track displays. Since the LED

bulbs produce white light, this test gave us enough confidence on the effect of color combinations.

From the test using the plastic gel sheets, we found that the dark blue seems to work best in clearly displaying the tracks. We think this is due to the fact that the blue color filters out light scattered from vapor molecules, leaving on the real tracks more prominently displayed. In order to test our theory, we displayed our chamber into the foyer of the building and asked random passersby to look into the chamber and point out what they see. We learned that while the filter reduces the intensity of the light, it made the actual interesting tracks more prominent, helping people who do not know what to look for more easily identify the tracks.

Based on this exercise, we decided to coat the clear display portion of the chamber with a blue plastic filter to reduce the glare from uninteresting liquid vapor and at the same time clearly display the actual tracks.

5. Liquid Supply System

5.1 Design Requirements

The liquid supply and circulation system for the LPCC must be designed so that the visual compartment of the cloud chamber can be furnished with a constant supply of isopropyl alcohol that that will be regularly both circulated and heated. Moreover, to initiate a self-contained circulation process, the excess accumulation of isopropyl alcohol along the bottom of the chamber due to condensation must be systematically extracted.

All these said components must adhere to the more general guidelines previously mentioned in Section 2, namely the liquid supply and circulation system must be safe and reliable; it must be capable of continuous function without fail and without regular maintenance; and it must be aesthetically appealing to the audience. The last condition will in particular apply to maintaining the level of noise produced by an operational pumping unit, as well as minimizing the appearance of the circulation tube's entrance and exit to the chamber. Most importantly however, safety will be given paramount attention.

The initial design depicted in Fig. 4 illustrates the requirements upon each component

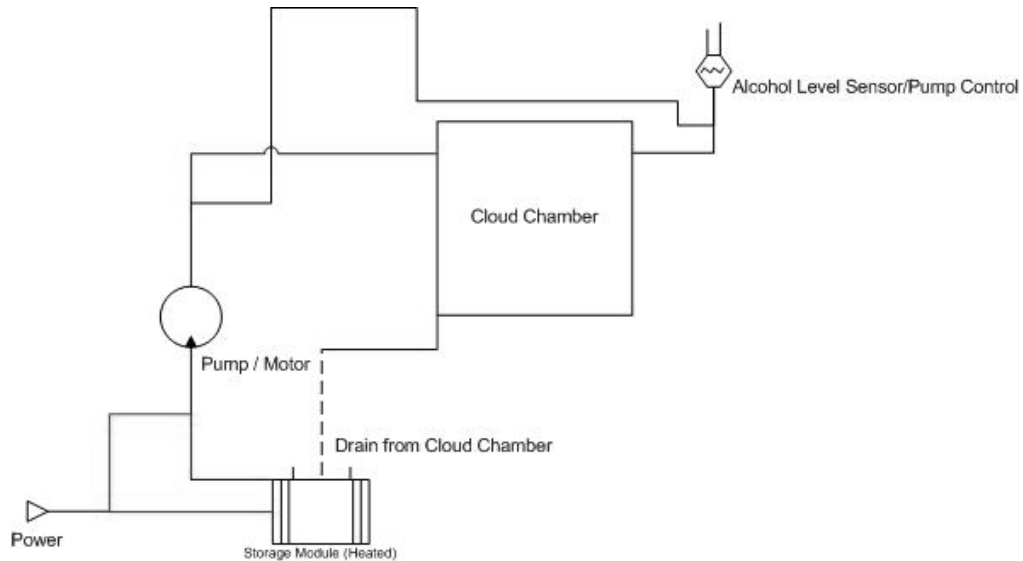

Figure 2 Preliminary design of the Liquid Supply and Circulation System.

of the system and demonstrates the thought process behind each element. However, it should be stated that this first draft has been improved for the final design.

The preliminary design of the liquid supply and circulation system contained a heated storage module where the isopropyl alcohol drained in from the cloud chamber. This served the dual purpose of providing a tank with which to store all necessary isopropyl alcohol, as well as contributing a heating system. Connected to the storage/heating module was a pump, with motor, that would drive alcohol into the cloud chamber's troughs. This component was one of the major circulation elements, granting a link between the storage/heating unit and the chamber itself. To the trough an alcohol level sensor was connected, enabling control over the pump and volume of liquid supplied. This element of the design contributed an important level of regulation over the process by enabling the operators of the LPCC to have the ability to manipulate the fine, inner workings of the machinery. Lastly, there was an exit mechanism along the bottom of the chamber to remove the isopropyl alcohol condensation and return the liquid alcohol to the supply/heating module. This was the last link in the circulation procedure, providing a completely cyclical system that could theoretically operate continuously on a set volume of isopropyl alcohol.

As previously mentioned changes obviously had to be made. First, there appeared a safety issue in the storage/heating module, where it was decided that having a continuous storage of a relatively large amount of heated alcohol could prove to be too volatile for continued operation. Additionally, this storage/heating module was designed as a completely open system, which turned out to be an obvious operational problem. These complications were remedied relatively simply by dividing the dual responsibilities of the storage/heating module into an individual supply reservoir that holds the entire body of isopropyl alcohol and a separate heat bath that warms it. Consequently, the pumping system had to be altered to accommodate the changes in general structure and geometry.

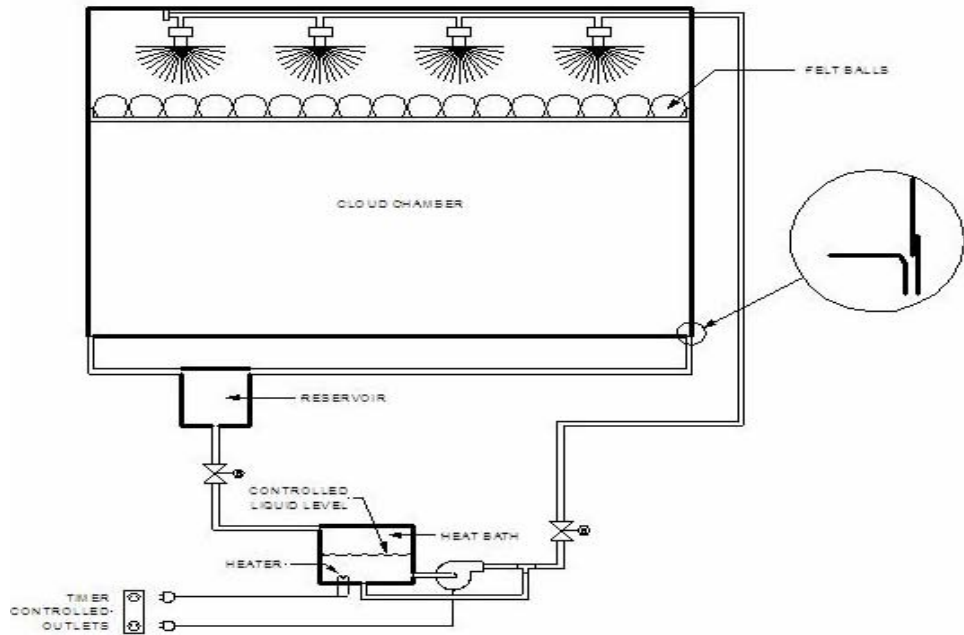

Figure 5 A schematic diagram of the final design of the Liquid Supply and Circulation System. The inset shows the liquid a perceived exit and recirculation mechanism.

Lastly as a further consequence of the addition of a distinct heat bath, the electronic liquid sensor was exchanged for a series of timed valves which would serve both the original purpose of day-to-day manipulation as well as conquer a few of the geometrical complications.

5.2 Final Design

The final design that was developed for the liquid supply and circulation system can be broken down into a series of four interlocking features: the alcohol reservoir, the heat bath and pump system, the liquid's ejection onto the chamber's evaporation troughs, and the exit process of the alcohol accumulation. A schematic diagram of this final design is shown in Fig. 5.

5.2.1 Isopropyl Alcohol Reservoir

The first component of the chamber's liquid supply system will be a sufficiently large, well-insulated reservoir with which the entire supply of isopropyl alcohol for the chamber will be stored. This volume will be a pre-measured initial stock sufficient for the chamber to continue operation for an extended period of time. For the final design, the exact amount of isopropyl alcohol that will be adequate for the chamber's necessary operation will need to be either calculated or found experimentally.

This reservoir will be constituted of plastic and placed somewhere below the chamber in order to facilitate the extraction of the cloud chamber's isopropyl alcohol condensation by means of gravity (see section 5.2.4: Exit Mechanism for Chamber's Isopropyl Alcohol Accumulation). Additionally, for gravity to also initiate the removal of isopropyl alcohol from the reservoir itself and then subsequently insert it into the heat bath, the reservoir will need to be placed somewhere above the bath.

The plastic reservoir will have ¼" silicon micro-tubing leading from the chamber's exit mechanism into a plastic adaptor connected to the top of the reservoir, so that the chamber's isopropyl alcohol condensation can recollect in order to be circulated again. This adaptor could also be used as input for future isopropyl alcohol necessary to keep the system functional. At the bottom of the reservoir, a similar plastic adaptor will be connected to the first electronically automated timed valve. This valve will open and close at regular, timed intervals releasing only the required amount of isopropyl alcohol that will be needed for dispersal into the chamber's evaporation troughs. Again, this exact volume of isopropyl alcohol will need to be either measured or calculated and the valve's timed interval set accordingly.

5.2.2 Heat Bath and Pump System

After the isopropyl alcohol is emitted from the initial plastic reservoir, it will descend

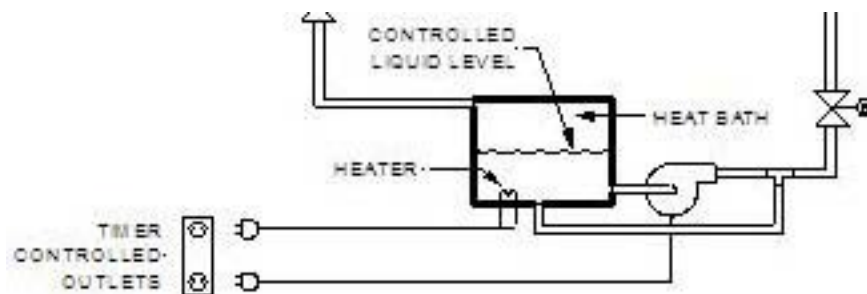

Figure 6 A schematic diagram of the heat bath and pump system

into a second reservoir, the heat bath, where the alcohol will be warmed in order to promote a faster evaporation rate before emission onto the chamber's evaporation troughs as shown in Fig. 6. The heat bath will be either a plastic, ceramic, or metal compartment that is extremely well-insulated and primarily closed from the rest of the circulation system. The exact material will be chosen after further research and experiment to ensure prime thermal conductivity without sacrificing structural integrity.

A system of isolated heating coils will be attached to the bottom of the compartment to heat the isopropyl alcohol convectively. These heating coils will be activated by a timed electrical switch set to the moment when the first timed valve from the reservoir is shut, therefore attempting to minimize danger if there happens to be a fluke spark or electrical short. Also attached to this electrical switch will be a pump certified to handle flammable liquid that, for the moment, will be circulating the volume of isopropyl alcohol to secure an isothermal medium. The pump will be attached to the chamber and then to a plastic or metal T-connection.

The flow of isopropyl alcohol that is diverted into the stem of the T-connection will be sent back into the chamber by means of ½" silicon tubing, while the flow into the third side of the T will be stopped by the second timed valve. This second timed valve will be set so that the volume of emitted isopropyl alcohol will be exactly equal to the volume that was input by the first timed valve from the supply reservoir. In order to ensure that the pump will never dry run, a set volume of isopropyl alcohol will always need to be kept inside the heat bath. If the amount of isopropyl alcohol ejected from the heat bath is indeed exactly equal to the amount put in by the reservoir, then this volume will never change. The pump, connectors, and second timed valve are pictured in Fig. 7.

At the close of the second timed valve, the heating coils and pump will be turned off by the timed electrical switch. As stated previously, the timed intervals and isopropyl alcohol volumes will need to be either calculated or measured experimentally.

5.2.3. Liquid Ejection onto the Evaporation Trough

From the second timed valve, the isopropyl alcohol will be rushed along ½" silicon



Figure 7 A photograph of the prototype system that consists of a pump, connectors and second timed valve.

tubing shown in Fig. 8 into the cloud chamber itself in order to be sprayed onto felt or cotton material in the chamber's evaporation troughs. The isopropyl alcohol will be pumped into a series of plastic T-connections, 1/4" silicon micro-tubing, and 180 degree misters shown in Fig. 9 that will be strategically mounted to the ceiling of the cloud chamber in order to fully saturate the material within the troughs while eliminating or minimizing the overflow and splatter resulting from the isopropyl alcohol's trajectory. This process is illustrated in Fig. 10.



Figure 8. 1/2" silicon micro-tubing



Figure 9. 180 degree misters

The 1/2" silicon tubing will be connected by the plastic T-connections to a number of different lines of 1/4" silicon micro-tubing that will go to each of the troughs. Along each of these lines will be a number of 180 degree misters placed above the evaporation troughs, so that when the isopropyl alcohol is pumped through the 1/4" silicon micro-tubing line it is ejected along the length of the channel. From here the isopropyl alcohol will evaporate off of the cotton or felt material, then condense and accumulate along the bottom of the chamber.

5.2.4 Exit Mechanism for Chamber's Isopropyl Alcohol Accumulation

Once the isopropyl alcohol has started to collect at the bottom of the chamber, it will slowly disperse toward the edges. Here, it will be gradually collected by a structurally designed exit mechanism for discharge back into the supply reservoir.

At the edges of the chamber there will be a narrow, angled trench acting like a street gutter to funnel the excess isopropyl alcohol down into two lines of 1/4" silicon micro-tubing that will lead to the supply reservoir. When the liquid reaches the trenches gravity

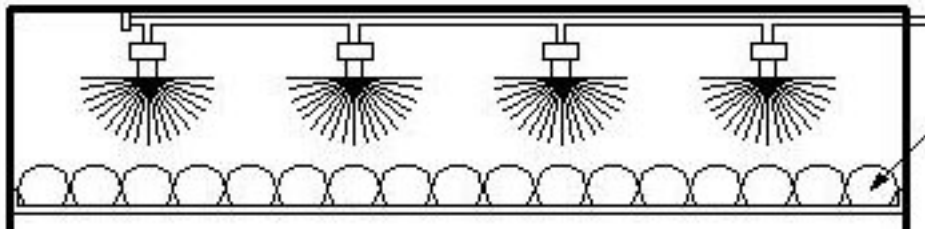

Figure 10 A schematic diagram of a series of Silicon Lines and 180 degree Mistors

will pull the droplets down the angled slope toward the two micro-tubing lines and then back into the reservoir to repeat the cycle. Theoretically, the holes into the discharge lines could be small enough to prevent the isopropyl alcohol vapor from escaping the chamber and making its way to the reservoir.

5.2.5 Future Improvements

As of now, the exit mechanism has not been assembled by the structure design team due to their own projects and time constraints. So therefore, it has not been tested. As a result, the caveat “theoretically” must be included within the description. However, it is believed that this process will indeed result in a contained isopropyl alcohol vapor cloud. Furthermore, it is of the utmost importance that the base of the chamber be as flat as possible to ensure that no liquid or vapor is being accelerated down a slope toward the accumulation trenches.

Additionally, there remains a significant amount of work in deciding the isopropyl alcohol volumes necessary to operate the system. Accordingly, the timed intervals necessary to transport these volumes by the timed valves is completely unknown. The exact measurements even for the prototype cloud chamber are of unknown quantity. Also, due to time constraints, the prototype of the heat bath has yet to be completed, so again the materials and structural fittings from the compartment to the pump system are indefinite.

Finally, due to the prolonged operation of the pump while the alcohol is being heated there will be an extended period of time where the noise of the pump may prove to be too loud for conventional usage.

5.3 Cost Estimate

Table 2 below shows a cost estimate for the liquid distribution system. The most expensive item is the pump that can safely circulate alcohol, a flammable liquid. Except for the pump, all material can be found at the local hardware store, such as Home Depot⁶, or online at the websites referenced. The Pond and Waterfall Pump is manufactured by Cyclone.

The ITT Jabsco Reversible Rotary Vane Pump, model number ITT186801000, could be purchased in place of the pond pump. This is a positive displacement pump used for volatile liquids and dry pumping, which could decrease hazards within the system. This pump is quieter and self-priming up to three feet with as little as eight amps used. It uses an off-center eccentric rotor with vanes sliding both inward and outward to create a vacuum within the pump to help pull liquid inside. The estimated cost for this product is \$300.

Table 2 Cost estimate for constructing the liquid supply system.

Material	Cost
Flammable Liquid Pump	\$300 - \$500
Sprinkler Timer	\$60
Watering Kit	\$50
Other (hoses, rubber washers, electrical tapes, etc)	\$50

6.0 Cooling System

Given the fact that LPCC would operate using temperature gradient and the concerns for public safety, we anticipated this system to be the most difficult to accomplish and to be the cost driver. Our research fun expenditure for this system was also the heaviest

among all other research topics. Below, we describe the research activities we carried out and the final conclusion for the proposed cooling system for LPCC.

6.1 Design Requirements

A cloud chamber requires a steep temperature gradient between its bottom and top surfaces. Using isopropyl alcohol as the liquid medium inside the chamber, a gradient of about 100° C is needed. If the top of the chamber is allowed to sit at room temperature, the most desirable bottom plate temperature is then -70° C.

In order for the chamber to be on continual display, it needs a self-contained perpetual cooling system requiring only infrequent maintenance. Any electrical components of the system need to have parts which can be easily accessed and replaced, without expert knowledge of the system. Any liquids used in the cooling will have to be replenished, but ideally not more than once a month. The system should be designed to run in perpetuity as long as there is a power source.

In addition to all the materials required to build the cooling system, maintaining it will require a certain yearly or perhaps monthly allowance. The most immediate cost is the electricity used. The system should use a reasonable amount of energy for the function it performs. Any liquids used should be commonly available for a university and not exorbitantly priced, and the system should not consume them at a gluttonous rate. Parts will have to be replaced from time to time, so they should be as simple and common as reasonably possible. The more exotic the hardware is, the more financially demanding the chamber will be in the future.

There are two safety issues that the cooling system team must consider. First, any hazardous chemicals used must be properly contained. Care should be taken in the design so that possible leaks will not cause the air to become toxic or flammable. Second, the hardware should be thoroughly inspected by an authority on electrical and fire safety. The chamber should be designed to plug in to a wall, which means very specific electrical ratings must be followed. A slight miscalculation can result in fire. If any part of the chamber catches fire, it will probably ruin the entire apparatus as well as endanger other property and people.

Since LPCC is for public display, it needs to have a master design that incorporates every component. In other words, all groups should decide together what it will look like. The cooling system specifically should be as small as reasonably possible, with no exposed wiring or tubes. Its noise level should be minimal, hopefully no more unpleasant than a refrigerator. In general it should appear to be professional, suitable for museum display.

6.2 Design Considerations

6.2.1 Thermoelectric Modules (TEM)

Originally our team chose thermoelectric modules (TEMs) as our cooling strategy to accommodate the original 10-layered cloud chamber design. Figure 11 shows a picture of a sealed TEM module and the top and bottom of the heat sinks. Using nothing but electricity, the sandwich-shaped TEMs generate heat on one side and cold on the other. The wafer-thin structure of the TEMs gave them a distinct advantage when we had only a few vertical centimeters between each chamber to create a large temperature gradient.

As part of our research, four TEM's and four heat sinks of equivalent length and width were purchased and their cooling ability needed to be tested. A brief description of how the TEM works is that the top gets incredibly cold when hooked up to a voltage

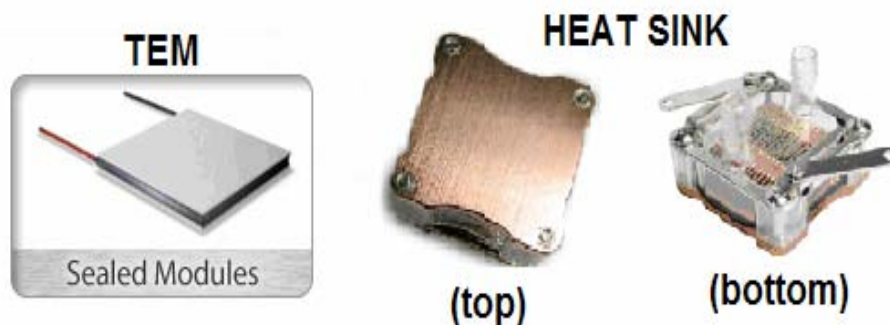

Figure 11 Pictures of a sealed Thermoelectric Module (TEM) and the top and bottom of the heat sink used in our research.

source. As a result, the bottom gets comparably hot – much too hot to handle. This problem of the hot side made the TEM difficult to work with and stunted our available cooling temperatures. This provided motivation for the heat sinks. Since the TEM chip sits directly on top of the heat sink, this particular model of heat sink is perfect because it is the exact same size as the TEM and cools off the scorching side of the chip. In doing so, the heat sink provides assistance by allowing an even cooler surface of the TEM chip. By running ice cold water through it and creating a very cool copper top, the bottom of the TEM chip is drastically cooled off. Because the TEM is so thin, a very hot bottom creates a cap of how cold the temperatures are allowed on the top. By lessening the heat of the bottom, the temperature cap is raised. Figure 12.a shows our TEM experiment setup, and 12.b shows another commercially available TEM purchased from a local electronics store.

Once the hot side of TEMs were adequately cooled down using the water cool system, the lowest temperature measured on the top surface of the TEM was -34°C . This was disappointing because the statistics of the TEM and heat sinks provided us with an expected value of perhaps -50°C . This measurement was taken with a laser thermometer

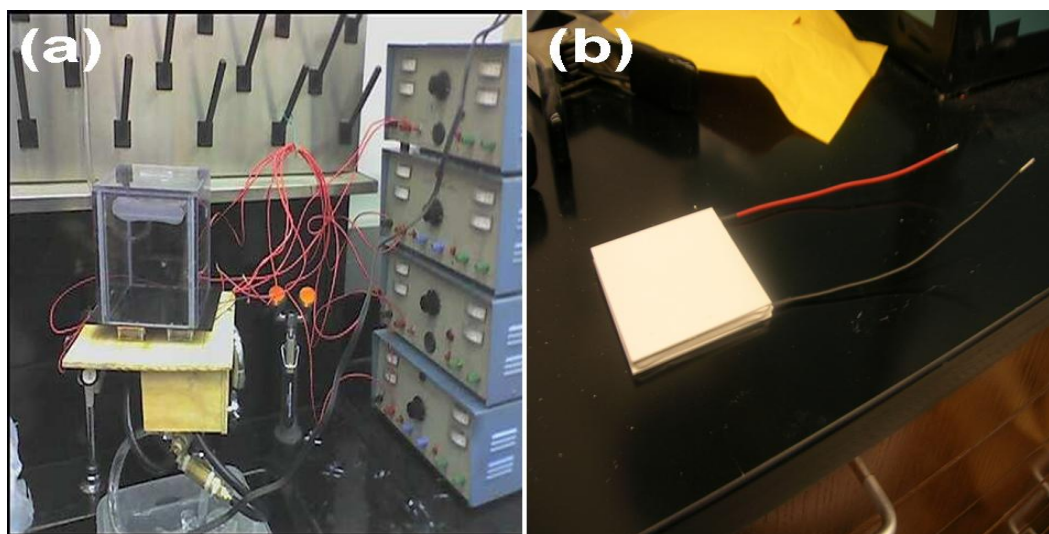

Figure 12 (a) Experimental setup for four TEM operations with the smallest prototype chamber CC#3 (b) A photograph of one of the TEMs used in the experiment.

so as to not disturb the surface being measured.

It is important to mention that the screws on top of the heat sink provided a very small, but still existent, distance between the copper top and bottom of the TEM. Direct contact is desired for optimal cooling. This problem was easily fixed by applying a uniform coat of thermal grease between the heat sink and TEM.

The next step was to arrange the four systems in a square with a small amount of distance between them and place the aluminum plate that supports the rest of the chamber on top to measure the amount of distributed cooling. The lowest temperature measured on this new surface was -11°C . This result was also disappointing but expected from the measurements taken from direct testing on the TEM chips. The same two TEM's were tested multiple times before testing all four simultaneously to be sure of consistent measurements. This may have worn down those two whereas the other two unused TEM's were operating as optimal as possible when applied to the system. This is also a contributing problem to the unachieved temperature goal of -30°C .

While we did not achieve our temperature goal of -78°C , the possibility of accomplishing this temperature or sufficiently low temperature is within our reach. We are much more familiar to the many characteristics of the TEM chips and how to operate them optimally. Unfortunately, this understanding came at the cost of overworking two of them. In the future, I believe that if two more were purchased, individual tests would not need to be run on them before applying them to the system and getting at least -20°C . To take us the extra mile to our goal, the heat sinks should not be running on a bucket of ice water because that takes away the perpetual idea. Instead, the heat sinks should be hooked up to the water system that runs through the building. Depending on how much better or worse that cools the TEM's, we could perhaps apply more than four TEM's in a system.

TEM were small ($3\text{cm}\times 3\text{cm}$), however, and thus on the order of 1100 would be required to cool $1\text{m}\times 1\text{m}$ cold plate for LPCC. Since each TEM costs over \$40, the total cost just for TEMs to cover one later is estimated to be over \$44,000. In addition, their cooling power was smaller than we'd hoped given the power each TEM draws (100 – 200W DC). The sustainability and the low maintenance requirements were also unsatisfactory given the wide range of fluctuation we experienced during the research with TEM.

Based on the research, we conclude that TEM is a good candidate for fitting in the small physical space for multiple layer chambers but the technology is not sufficiently robust for us to use for this purpose. In addition the cost for construction as well as the cost for operation does not seem feasible at this moment.

6.2.2 Cooling via Liquid Compression and Expansion

After it has been determined that constructing 10-layered chamber is too costly and the operation of TEM is much more difficult in large scale, we decided to look into the use of a more traditional method. The most common refrigeration design is the compression/expansion system. A liquid is allowed to expand into a gas and is subsequently compressed back into a liquid. This process causes a net heat flow from one side to the other.

Compression/expansion systems are difficult to build in laboratories without sufficient expertise and funds and cooling to -70°C requires using more dangerous



Figure 13 (a) Solid Al cold plate and a pump (b) An experimental setup that utilized gravitational force to supply LN2 into the cold plate

coolants such as liquid nitrogen. Despite our extensive searching, we were unable to find a vendor that would make the parts to our specifications for cooling 1mx1m area.

To study this, we acquired an all aluminum solid cold plate, some liquid nitrogen, a pump, and some polyurethane tubing. Figure 13.a shows the solid Al cold plate and the pump, and Fig. 13.b shows an experimental setup that supplies LN2 into the Al cold plate using gravitational force.

We pumped the liquid nitrogen into a commercially available Al cold plate, but the heat from the pump caused the nitrogen to evaporate prematurely, preventing sufficient flow of LN2 through the cooling plate. Next we used gravity by simply pouring the nitrogen into a funnel and waiting for it to flow downward through the plate. It took about 15 minutes of continuous LN2 supply for the cold plate to reach -70°C due to internal heat in the delivery system and the cold plate took about 15 minutes.

While the plate achieved the desired temperature, the compression/expansion cooling system remains out of reach without proper expertise in engineering, as well as equipment and facilities suited to the task.

6.3 Behavior of Alcohol and Floating ΔT

One of the research items concerning a perpetually running cloud chamber that uses TEM modules described in the previous section is the possibility of creating a super-saturated state of the liquid, most likely the isopropyl alcohol, without cooling to the dry-ice temperature. If super-saturation occurs (as long as there is the temperature gradient of close to 100°C) with the minimum temperature below the alcohol freezing point, we can use TEM's with a reasonably low temperature of chilled water ($\sim 40^{\circ}\text{F}$ or 5°C) that is provided throughout the new Chemistry and Physics building at UTA. Since TEM's can create the temperature difference between the cold side and warm side to $60 - 70^{\circ}\text{C}$, then theoretically and we have accomplished the cold-side temperature down to -34°C . As described in the previous section, we could imagine creating the total temperature difference of close to 100°C by heating up alcohol above the room temperature and accomplishing the TEM's cold-side temperature to a reasonably achievable $-40 - -50^{\circ}\text{C}$. This ability is also important if the chamber height were to be shortened since the

temperature inside the chamber will eventually equalize more quickly due to the cold bottom plates than for the taller chambers.

We tested this during the workshop in April, 2006. We warmed up alcohol to about 50°C and used the warm alcohol in the short chamber (10cm tall) whose bottom plate was chilled by dry-ice. We observed that very thick super-saturated layer of alcohol was obtained and the chamber started operating much sooner than a tall chamber (30cm) with the alcohol at room temperature. From this result we conclude that we could use alcohol of a higher temperature to generate a better functioning chamber, and it is possible for us to use TEM's that cools the bottom plate colder than dry-ice.

Even after concluding that TEMs are impractical to use for LPCC, we still found that keeping alcohol at a warmer temperature to increase the effectiveness of the chamber attractive. For this reason, as described in previous sections, we have decided to have a heat bath in the liquid supply system to keep alcohol slightly higher temperature but sufficiently low to prevent spontaneous ignition of alcohol vapor during the operation.

6.4 Commercially Available Cooling System

Testing different types of cooling systems confirmed several things we had suspected in the beginning. First, building a complex machine requires spending a lot of money on prototypes and testing materials. All developers understand that the initial costs of designing and testing a product will far outweigh the cost of building the final product. A common quip from the pharmaceutical industry illustrates this point: "The first pill costs fifty million dollars; the second pill costs a nickel." Since commercially built coolers have been on the market for a long time, it will inevitably be cheaper to buy "the second pill."

Second, building an uncommonly powerful, perpetually running refrigeration system requires extensive knowledge of refrigeration. Any such machine designed and built by inexperienced people is certain to be an inferior product, and possibly unsafe.

For these reasons we believe the best option is to buy a commercially built cooler. It will be cheaper, safer, and more efficient. While it may seem disappointing to buy one of the components to the chamber without building it, most of the cloud chamber will still have to be designed and built by student hands. A commercially designed cooler will assure the chamber runs smoothly and successfully, so that the public can enjoy its beauty.

6.5 Final Design

Our proposal for the final design is a commercially built cooler. These coolers are available from a variety of vendors. For example, the Neslab ULT-80 (shown in Fig. 9), available from www.thermo.com has a cooling capacity of 250 Watts at -70° C. This or a similar cooler would be powerful enough to achieve our needs. It, however, is necessary for our group to design the interface between these commercially available units to the bottom cold plate of the LPCC. In addition, the integration of the cooling unit into the base of the LPCC needs to be thought out. However, this can only happen when the purchase of a commercial system is made so that we know the dimension of the unit. The cost of the NESLAB ULT-80 (shown in Fig. 14) Ultra-low temperature bath to be purchased from Thermal Industries is \$13,533.00. The contingency is \$4,059.90. The total estimated cost for this commercial cooling system (including the contingency) is \$17,592.90. (For info. URL <http://www.atecorp.com/Equipment/Neslab/ULT80.htm>).



Figure 14 A photo of NESLAB ULT-80 ultra-low temperature bath

For cooling system, we have tested two types of cooling systems and analyzed with the goal of attaining necessary temperatures for a vapor to be created in a cloud chamber. The TEM was the hope that spent the majority of our efforts on this project. Different heat sinks were used in conjunction with the TEMs to achieve a theoretically lower surface temperature of the ceramic cold side of the TEM. When one heat sink failed, a certain lesson was learned and the next product was purchased with this new awareness in mind. Our last purchase was extremely successful but would require much more development before implementing it into the total cloud chamber system. With the knowledge of this data, purchasing a manufactured cooling system is the conclusion that has been reached.

7. Prototype Demonstrations with Dry Ice

We used the CC#1 with the new high lumen LED bulb during the UTA's new Chemistry and Physics building opening ceremony, held in March 3 and 4, 2006. Especially, the public demonstration of the chamber on Saturday, March 4, drew more than 500 people. We projected the chamber's tracks onto a large screen in a new computing center. The visitors of all ages, especially young children, were so attracted to the beauty and wonder of the tracks of cosmic and background radiation particles that many of them did not want to leave the chamber. We have also put together a poster that explains the cloud chamber project at UTA and distributed it to the visitors to aid their understanding of the project. Figure 15 shows two photos of the CC#1 in action during the building opening ceremony. It was learned after the exhibition that the cloud chamber was the best attraction in the entire celebration.

CC#1 was subsequently taken to the Texas section APS meetings in San Angelo, TX, in April, 2006, and at the University of Texas at Arlington in September 2006. It was

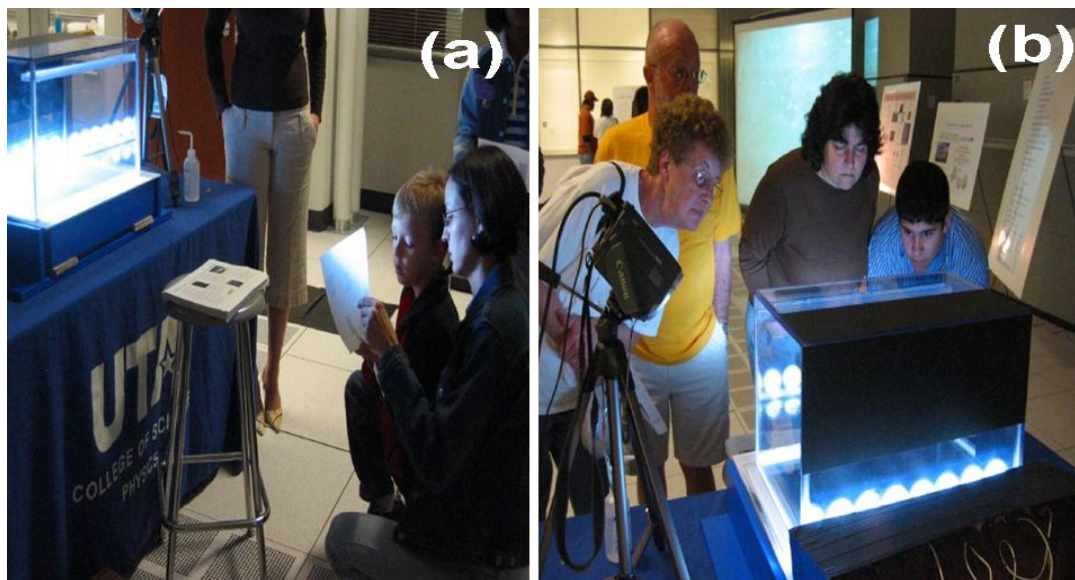

Figure 15 Two photos of the cloud chamber exhibit during the UTA's Chemistry and Physics Building opening public event. The chamber is visible with all of its eight LED lights illuminating. learned that the students at the Texas section meeting have never seen a cloud chamber in action before. The chamber again was an attraction at both the meetings. Notably, UTA's provost Dr. Dana Dunn who is a social scientist made an explicit comment on the excitement she experienced observing the tracks displayed in the large prototype chamber. She represents well the enthusiasm and support of the university administration to our LPCC project.

CC#1 chamber was frequently used in public events and other activities at UTA. Ibe used at the QuarkNet high school teacher program held in the week of June 12 and will be used for a 6th – 8th grade pre-engineering program in July.

While the prototype chambers serve our research in understanding issues with the large cloud chamber, they certainly are attractive features for general public and K-12 students in demonstrating to them of the wonder in nature that they do not see with their naked eyes.

We have also had many public displays to K-12 students, notably we took the chamber to Dr. Yu's lecture to TexPrep 7th – 8th grade students who are taking special summer advanced engineering classes.

7. Conclusions

With the National SPS chapter grant, the UTA LCCS was able to complete virtually all research topics toward its original goal of building a large scale perpetual cloud chamber (LPCC). From the research in the past year, we concluded that ½" polycarbonate plastic sheets with the joint design as shown in Fig. 1 are sufficient for the final version of the chamber. Given the low cost of the 99% isopropyl alcohol, we will use it as the primary liquid that generates the super-saturated layer. We also learned that we could warm up alcohol to 50°C to generate super-saturated state more rapidly. This gave the possibility of shifting the overall temperature range up, maintaining the temperature gradient, to accomplish the super-saturated state of the alcohol.

We also designed and constructed LED light strip with a limited illumination to minimize glare from vapor molecule. Since LED's consume very little electricity and

have superb lifetime, they not only impact little to the overall temperature gradient and is suitable choice for LPCC.

We finalized the design of the continuous alcohol supply system and implemented to the large prototype chamber (CC#1). We have learned that our original plans for using TEMs is not cost effective nor reliable since the TEM's draw large amount of DC current and the performance fluctuate wildly between operations. A subsequent study on constructing a LN2 based system demonstrated its difficulty in designing such a system with adequate safety. We therefore have decided to use commercially available cooling system for the final LPCC.

Since the research topics for LPCC are at sufficiently high levels, Dr. Yu has made them special project for his Nuclear and Particle Physics course. This enabled some of the cost to be covered as an expense for the class since it is part of an activity, creating a new course material.

In conclusion, the research accomplishments reported in this document represent a tremendous amount of work of the LCCS group. These research accomplishments enable LCCS to present the final design and look for suitable funding sources. The UTA LPCC will be a one layer, horizontal chamber with the viewing chamber dimension of 200cm (W)×50cm (D)×50cm (H). It will have a commercial refrigeration system with LED light strip we will construct. LPCC will also have the perpetual liquid supply system this research resulted in and that constructed by LCCS at UTA.

We also have a semi-perpetual prototype chamber (CC#1) that can be used until the final LPCC completes. Achieving all these in such a short time scale would have been very difficult or flat out impossible without the funds provided through the National Chapter of SPS program and the strong support from the UTA physics department and the administration.

Acknowledgements

We would like to thank the National Chapter of SPS and the department of physics and the dean's office of the college of Science of UTA for providing funds for our research. We also would like to thank the chairman of the physics department and the dean of the college of science and the provost of the University of Texas at Arlington for their strong support and interests in our large cloud chamber research project.